

OPERATOR'S MANUAL

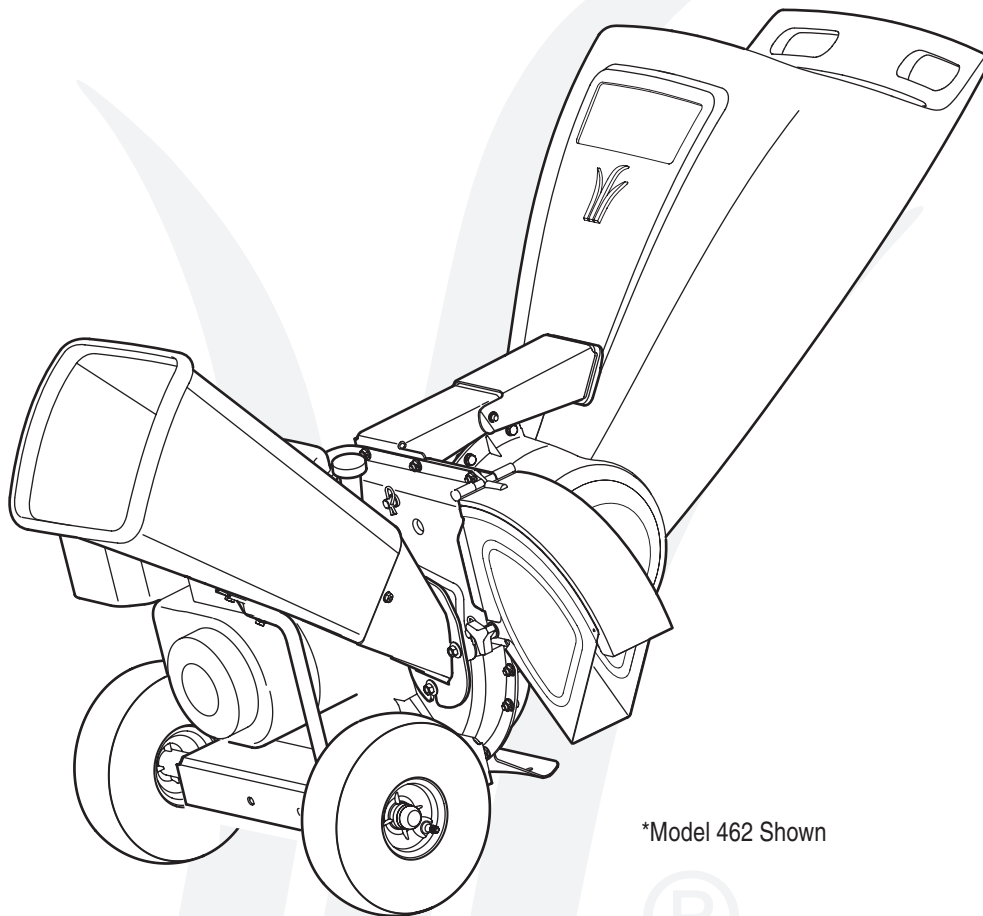

*Model 462 Shown



Chipper Shredder — Model Series 452 thru 465

IMPORTANT

READ SAFETY RULES AND INSTRUCTIONS CAREFULLY BEFORE OPERATION

Warning: This unit is equipped with an internal combustion engine and should not be used on or near any unimproved forest-covered, brush-covered or grass-covered land unless the engine's exhaust system is equipped with a spark arrester meeting applicable local or state laws (if any). If a spark arrester is used, it should be maintained in effective working order by the operator. In the State of California the above is required by law (Section 4442 of the California Public Resources Code). Other states may have similar laws. Federal laws apply on federal lands. A spark arrester for the muffler is available through your nearest engine authorized service dealer or contact the service department, P.O. Box 361131 Cleveland, Ohio 44136-0019.

This Operator's Manual is an important part of your new chipper shredder. It will help you assemble, prepare and maintain the unit for best performance. Please read and understand what it says.

Table of Contents

Customer Support.....	2	Maintaining Your Chipper Shredder.....	12
Safety Labels	3	Troubleshooting.....	14
Safe Operation Practices	4	Parts List	16
Setting Up Your Chipper Shredder.....	6	Warranty	Back Cover
Operating Your Chipper Shredder.....	10		

Finding and Recording Model Number

BEFORE YOU START ASSEMBLING YOUR NEW EQUIPMENT, please locate the model plate on the equipment and copy the information to the sample model plate provided to the right. You can locate the model plate by standing behind the unit and looking down at the frame below the engine. This information will be necessary to use the manufacturer's web site and/or obtain assistance from the Customer Support Department or an authorized service dealer.

Model Number	Serial Number
	MTD LLC P.O. BOX 361131 CLEVELAND, OH 44136 330-220-4683 800-800-7310

Customer Support

Please do **NOT** return the unit to the retailer from which it was purchased, without first contacting Customer Support.

If you have difficulty assembling this product or have any questions regarding the controls, operation, or maintenance of this unit, you can seek help from the experts. Choose from the options below:

1. Visit **mtdproducts.com**. Click on Yard Machines and then the Customer Support menu option.

Yard-Man	Yard Machines	Manuals Online	Parts Online	Service Locator	Product Registration
----------	---------------	----------------	--------------	-----------------	----------------------

Need help using this site? Find instructions [here](#).

When searching this site, using fewer key words is more efficient than sentences or long phrases.

Answers	My Stuff	Login	Help
Products & Services ⓘ	Search Text (optional)	Search Tips	
All Products	<input type="text"/>	Search	
	Search by		
	Similar Phrases		
		Powered by RightNow	

2. Phone a **Customer Support Representative** at 1 (800) 800-7310.
3. The **engine manufacturer** is responsible for all engine-related issues with regards to performance, power-rating, specifications, warranty and service. Please refer to the engine manufacturer's Owner's/Operator's Manual, packed separately with your unit, for more information.

⚠ DANGER

TO AVOID SERIOUS INJURY:

- Do not operate on uneven ground where unit is unstable. Do not operate on pavement, gravel or other hard surfaces since objects can ricochet and cause injury.
- To avoid a fire hazard, keep leaves, grass, and other combustible materials away from hot engine and muffler.
- Keep children and others away from area of operation.
- Wear approved safety glasses, gloves and ear protection.



**INSTRUCTIONS:
TO RAISE AND LOWER HOPPER**



⚠ DANGER

TO AVOID SERIOUS INJURY:

- Read the owner's manual(s) before starting and using unit.
- Keep all shields and guards in place and securely attached.
- Keep hands, feet, face, clothing and long hair out of Shredder Hopper, Chipper Chute and Discharge Chute while the engine is running. Rotating cutting blades inside these openings will cause serious personal injury if contacted. Material being processed may bounce back from inlet openings or be thrown from the discharge chute. Long hair or loose clothing may be pulled sucked into the inlet openings.
- Do not place branches over 1/2 inch diameter into the large Shredder Hopper. Branches over 1/2 inch in diameter should be placed in the Small Chipper Chute.
- If the chipped shredder jams or becomes clogged, immediately shut off the engine and wait for all moving parts to come to a complete stop before clearing.
- Do not install, remove, adjust, or service the discharge screen or any other part while the engine is running. Blade contact can occur.

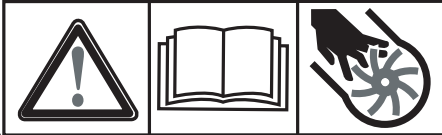

⚠ DANGER

ROTATING CUTTING BLADES. KEEP HANDS AND FEET OUT OF OPENINGS WHILE MACHINE IS RUNNING.



⚠ DANGER

- ROTATING CUTTING BLADES. KEEP HANDS AND FEET OUT OF OPENING WHILE MACHINE IS RUNNING.
- DO NOT OPERATE THIS MACHINE UNLESS THE CHUTE DEFLECTOR HAS BEEN PROPERLY INSTALLED AND IS SECURED WITH THE HAND KNOBS.



⚠ WARNING

TO AVOID EYE INJURY, WEAR SAFETY GLASSES.



DO NOT DEPOSIT MATERIAL LARGER THAN 1/2" DIAMETER IN LARGE SHREDDER HOPPER. THIS MAY DAMAGE MACHINE.

⚠ DANGER

ASSEMBLE CHUTE DEFLECTOR TO THIS UNIT BEFORE OPERATING MACHINE.

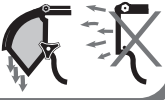

1

Safety Labels



WARNING

This symbol points out important safety instructions which, if not followed, could endanger the personal safety and/or property of yourself and others. Read and follow all instructions in this manual before attempting to operate this machine. Failure to comply with these instructions may result in personal injury. When you see this symbol.

HEED ITS WARNING!

Your Responsibility

Restrict the use of this power machine to persons who read, understand and follow the warnings and instructions in this manual and on the machine.

This Operators Manual covers a range of product specifications for various models. Characteristics and features discussed and/or illustrated in this manual *may not* be applicable to all models. MTD LLC reserves the right to change product specifications, designs and equipment without notice and without incurring obligation.

2

Safe Operation Practices



WARNING

This symbol points out important safety instructions which, if not followed, could endanger the personal safety and/or property of yourself and others. Read and follow all instructions in this manual before attempting to operate this machine. Failure to comply with these instructions may result in personal injury. When you see this symbol.

HEED ITS WARNING!

Your Responsibility

Restrict the use of this power machine to persons who read, understand and follow the warnings and instructions in this manual and on the machine.



WARNING: Engine Exhaust, some of its constituents, and certain vehicle components contain or emit chemicals known to State of California to cause cancer and birth defects or other reproductive harm.

DANGER: This machine was built to be operated according to the rules for safe operation in this manual. As with any type of power equipment, carelessness or error on the part of the operator can result in serious injury. This machine is capable of amputating hands and feet and throwing objects. Failure to observe the following safety instructions could result in serious injury or death.

Training

1. Read, understand, and follow all instructions on the machine and in the manual(s) before attempting to assemble and operate. Keep this manual in a safe place for future and regular reference and for ordering replacement parts.
2. Be familiar with all controls and their proper operation. Know how to stop the machine and disengage them quickly.
3. Never allow children under 16 years old to operate this machine. Children 16 years old and over should read and understand the operation instructions and safety rules in this manual and should be trained and supervised by a parent.
4. Never allow adults to operate this machine without proper instruction.
5. Keep bystanders, helpers, pets, and children at least 75 feet from the machine while it is in operation. Stop machine if anyone enters the area.
6. Never run an engine indoors or in a poorly ventilated area. Engine exhaust contains carbon monoxide, an odorless and deadly gas.
7. Do not put hands and feet near rotating parts or in the feeding chambers and discharge opening. Contact with the rotating impeller can amputate fingers, hands, and feet.
8. Never attempt to unclog either the feed intake or discharge opening, remove or empty bag, or inspect and repair the machine while the engine is running. Shut the engine off and wait until all moving parts have come to a complete stop. Disconnect the spark plug wire and ground it against the engine.

Preparation

1. Thoroughly inspect the area where the equipment is to be used. Remove all rocks, bottles, cans, or other foreign objects which could be picked up or thrown and cause personal injury or damage to the machine.
2. Always wear safety glasses or safety goggles during operation or while performing an adjustment or repair, to protect eyes. Thrown objects which ricochet can cause serious injury to the eyes.
3. Wear sturdy, rough-soled work shoes and close-fitting slacks and shirts. Loose fitting clothes or jewelry can be caught in movable parts. Never operate this machine in bare feet or sandals. Wear leather work gloves when feeding material in the chipper chute.
4. Before starting, check all bolts and screws for proper tightness to be sure the machine is in safe working condition. Also, visually inspect machine for any damage at frequent intervals.
5. Maintain or replace safety and instructions labels, as necessary.
6. To avoid personal injury or property damage use extreme care in handling gasoline. Gasoline is extremely flammable and the vapors are explosive. Serious personal injury can occur when gasoline is spilled on yourself or your clothes which can ignite. Wash your skin and change clothes immediately.
 - a. Use only an approved gasoline container.
 - b. Extinguish all cigarettes, cigars, pipes, and other sources of ignition.
 - c. Never fuel machine indoors.
 - d. Never remove gas cap or add fuel while the engine is hot or running.
 - e. Allow engine to cool at least two minutes before refueling.
 - f. Never over fill fuel tank. Fill tank to no more than 1/2 inch below bottom of filler neck to provide space for fuel expansion.
 - g. Replace gasoline cap and tighten securely.
 - h. If gasoline is spilled, wipe it off the engine and equipment. Move machine to another area. Wait 5 minutes before starting the engine.
 - i. Never store the machine or fuel container inside where there is an open flame, spark, or pilot light (e.g. furnace, water heater, space heater, clothes dryer, etc.)
 - j. To reduce a fire hazard, keep machine free of grass, leaves, or other debris build-up. Clean up oil or fuel spillage and remove any fuel soaked debris.
 - k. Allow machine to cool at least 5 minutes before storing.

Operation

1. Do not put hands and feet near rotating parts or in the feeding chambers and discharge opening. Contact with the rotating impeller can amputate fingers, hands, and feet.
2. Before starting the machine, make sure the chipper chute, feed intake, and cutting chamber are empty and free of all debris.
3. Thoroughly inspect all material to be shredded and remove any metal, rocks, bottles, cans, or other foreign objects which could cause personal injury or damage to the machine.
4. If it becomes necessary to push material through the shredder hopper, use a small diameter stick. Do not use your hands or feet.
5. If the impeller strikes a foreign object or if your machine should start making an unusual noise or vibration, immediately shut the engine off. Allow the impeller to come to a complete stop. Disconnect the spark plug wire, ground it against the engine and perform the following steps:
 - a. Inspect for damage.
 - b. Repair or replace any damaged parts.
 - c. Check for any loose parts and tighten to assure continued safe operation.
6. Do not allow an accumulation of processed material to build up in the discharge area. This can prevent proper discharge and result in kickback of material through the feed opening.
7. Do not attempt to shred or chip material larger than specified on the machine or in this manual. Personal injury or machine damage could result.
8. Never attempt to unclog either the feed intake or discharge opening while the engine is running. Shut the engine off, wait until all moving parts have stopped, disconnect the spark plug wire and ground it against the engine before clearing debris.
9. Never operate without the shredder hopper, chipper chute, or chute deflector properly attached to the machine. Never empty or change discharge bag while the engine is running.
10. Keep all guards, deflectors and safety devices in place and operating properly.
11. Keep your face and body back and to the side of the chipper chute while feeding material into the machine to avoid accidental kickback injuries.
12. Never operate this machine without good visibility or light.
13. Do not operate this machine on a paved, gravel or non-level surface.
14. Do not operate this machine while under the influence of alcohol or drugs.
15. Muffler and engine become hot and can cause a burn. Do not touch.
16. Never pick up or carry machine while the engine is running.

Maintenance & Storage

1. Never tamper with safety devices. Check their proper operation regularly.
2. Check bolts and screws for proper tightness at frequent intervals to keep the machine in safe working condition. Also, visually inspect machine for any damage and repair, if needed.
3. Before cleaning, repairing, or inspecting, stop the engine and make certain the impeller and all moving parts have stopped. Disconnect the spark plug wire and ground it against the engine to prevent unintended starting.
4. Do not change the engine governor settings or overspeed the engine. The governor controls the maximum safe operating speed of the engine.
5. Maintain or replace safety and instruction labels, as necessary.
6. Follow this manual for safe loading, unloading, transporting, and storage of this machine.
7. Never store the machine or fuel container inside where there is an open flame, spark or pilot light such as a water heater, furnace, clothes dryer, etc.
8. Always refer to the operator's manual for proper instructions on off-season storage.
9. If the fuel tank has to be drained, do this outdoors.
10. Observe proper disposal laws and regulations for gas, oil, etc. to protect the environment.

Do not modify engine

To avoid serious injury or death, do not modify engine in any way. Tampering with the governor setting can lead to a runaway engine and cause it to operate at unsafe speeds. Never tamper with factory setting of engine governor.

Notice regarding Emissions

Engines which are certified to comply with California and federal EPA emission regulations for SORE (Small Off Road Equipment) are certified to operate on regular unleaded gasoline, and may include the following emission control systems: Engine Modification (EM) and Three Way Catalyst (TWC) if so equipped.

Your Responsibility

Restrict the use of this power machine to persons who read, understand and follow the warnings and instructions in this manual and on the machine.

2

Safe Operation Practices



WARNING

This symbol points out important safety instructions, which if not followed, could endanger the personal safety and/or property of yourself and others. Read and follow all instructions in this manual before attempting to operate this machine. Failure to comply with these instructions may result in personal injury. When you see this symbol.

HEED IT'S WARNING!

Your Responsibility

Restrict the use of this power machine to persons who read, understand and follow the warnings and instructions in this manual and on the machine.

3

Setting Up Your Chipper Shredder



IMPORTANT

This unit is shipped without gasoline or oil in the engine. Be certain to service engine with gasoline and oil as instructed in the separate engine manual before operating your machine.

NOTE: All references in this manual to the left or right side of the chipper shredder is from the operating position only. Exceptions, if any, will be specified.

NOTE: This Operators Manual covers a range of product specifications for various models. Characteristics and features discussed and/or illustrated in this manual *may not* be applicable to all models. MTD LLC reserves the right to change product specifications, designs and equipment without notice and without incurring obligation.

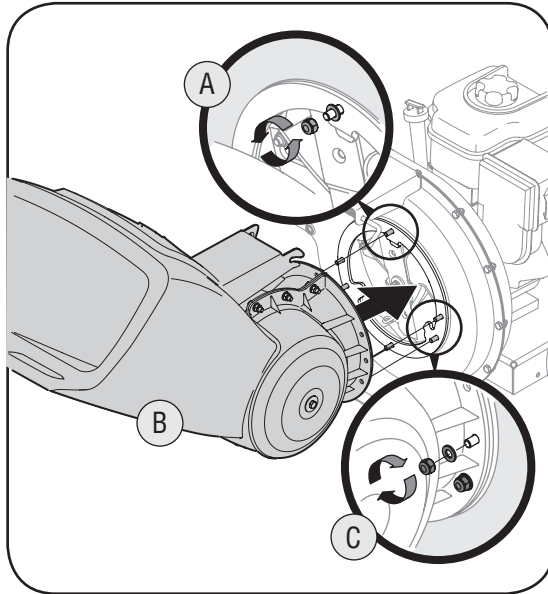

Figure 3-1

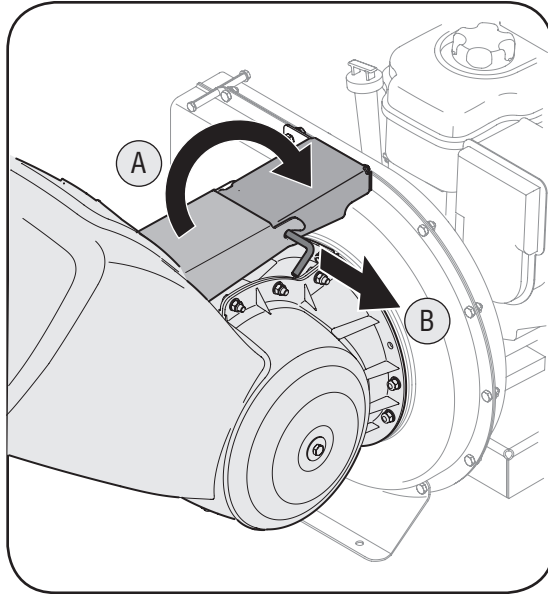

Figure 3-2

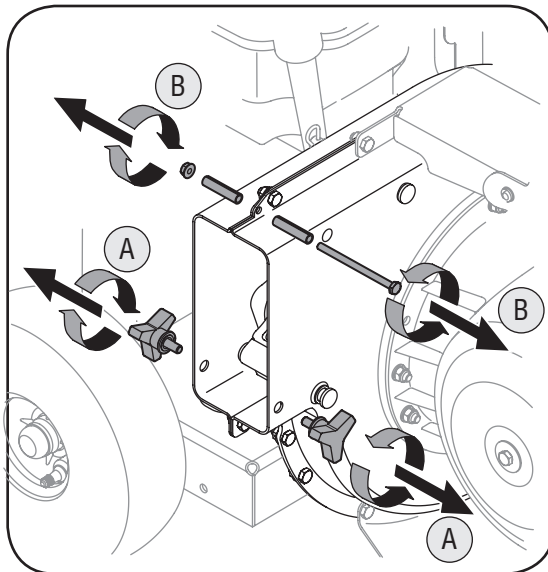

Figure 3-3

IMPORTANT: This unit is shipped without gasoline or oil in the engine. Be certain to service engine with gasoline and oil as instructed in the separate engine manual before operating your machine.

Loose Parts In Carton

- | | |
|--------------------|-------------------|
| a. Hopper Assembly | d. Bag |
| b. Chute Deflector | e. Safety Glasses |
| c. Chipper Chute | f. Engine Oil |

Attaching The Hopper Assembly

- Remove six hex nuts and washers from the weld studs on the impeller housing. Do not remove the support plate. See Figure 3-1.
 - Place hopper assembly into position in front of impeller housing, aligning holes in hopper assembly collar with weld studs.
 - Slide hopper assembly onto weld studs and replace washers and hex nuts. Do not tighten completely.
- Lift hopper assembly up to impeller bracket assembly.
 - Slide the release rod out slightly to hook the hopper bracket onto the rod. See Figure 3-2.
 - Tighten the six hex nuts that secure hopper assembly to impeller housing and also tighten the hex nuts that secure hopper bracket to hopper assembly.

Attaching The Chute Deflector

3. a. Remove the wing knobs from each side of the lower impeller housing.
b. Remove the hex lock nut, spacers, and hex bolt from the top of the impeller housing. See Figure 3-3.
4. a. Align the chute deflector in position on the discharge opening and insert hex bolt with spacer through hinge on chute deflector (spacers fit inside of hinges). See Figure 3-4.
b. Place second spacer over hex bolt inside other hinge and secure with hex lock nut.
c. Secure both sides of chute deflector to impeller housing using wing knobs previously removed.

Attaching The Chipper Chute (Model Series 460)

5. a. Remove the three cupped washers and hex nuts from weld studs around the opening on the side of the impeller housing. See Figure 3-5.
b. Remove the hex bolts, flat washers, and lock nuts from the two holes on the upper end of the support brace.
6. a. Align the chipper chute over the weld studs, so the slot in the bottom of the chute is facing down.
b. Secure chipper chute with the three cupped washers (cupped side against the chipper chute) and hex nuts previously removed. Do not tighten the nuts at this time. See Figure 3-6.

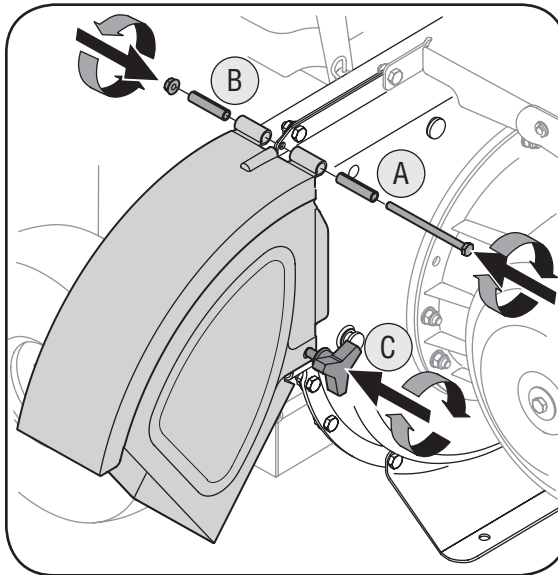

Figure 3-4

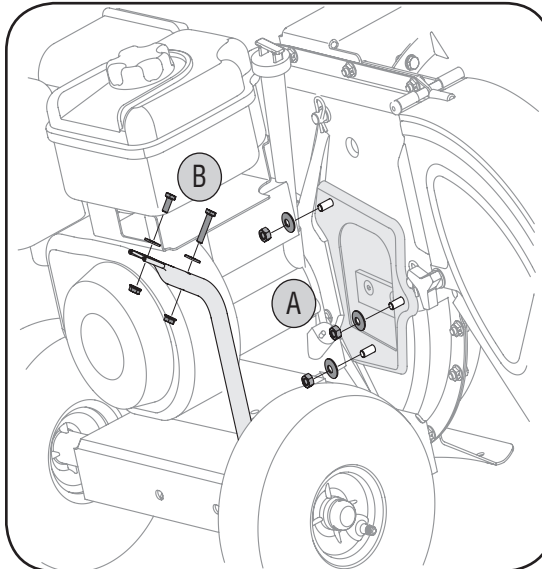

Figure 3-5

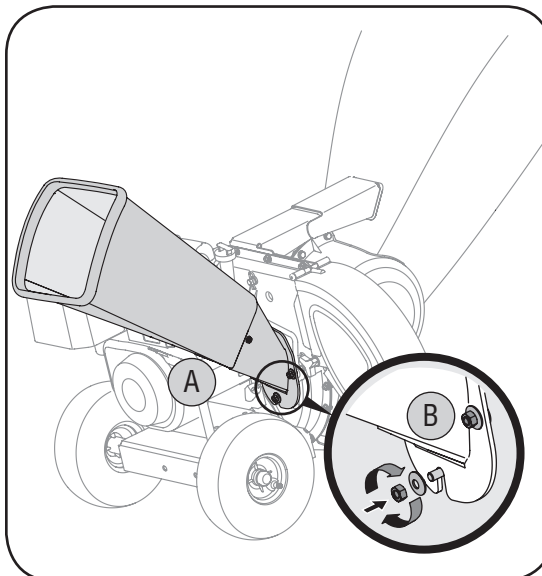

Figure 3-6

3

Setting Up Your Chipper Shredder



IMPORTANT

This unit is shipped without gasoline or oil in the engine. Be certain to service engine with gasoline and oil as instructed in the separate engine manual before operating your machine.

NOTE: All references in this manual to the left or right side of the chipper shredder is from the operating position only. Exceptions, if any, will be specified.

NOTE: This Operators Manual covers a range of product specifications for various models. Characteristics and features discussed and/or illustrated in this manual *may not* be applicable to all models. MTD LLC reserves the right to change product specifications, designs and equipment without notice and without incurring obligation.

3

Setting Up Your Chipper Shredder



IMPORTANT

This unit is shipped without gasoline or oil in the engine. Be certain to service engine with gasoline and oil as instructed in the separate engine manual before operating your machine.

NOTE: All references in this manual to the left or right side of the chipper shredder is from the operating position only. Exceptions, if any, will be specified.

NOTE: This Operators Manual covers a range of product specifications for various models. Characteristics and features discussed and/or illustrated in this manual *may not* be applicable to all models. MTD LLC reserves the right to change product specifications, designs and equipment without notice and without incurring obligation.

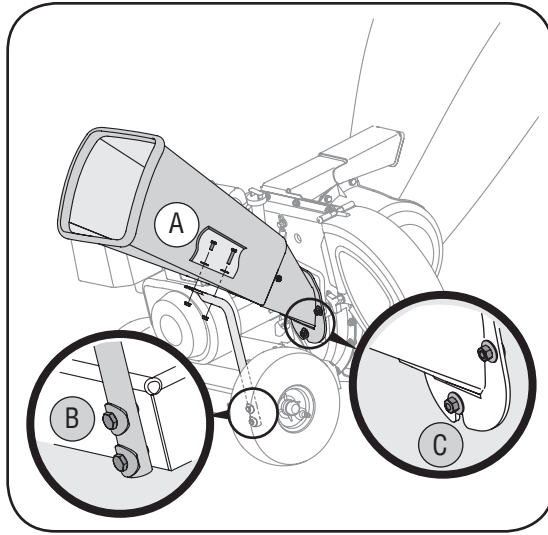

Figure 3-7

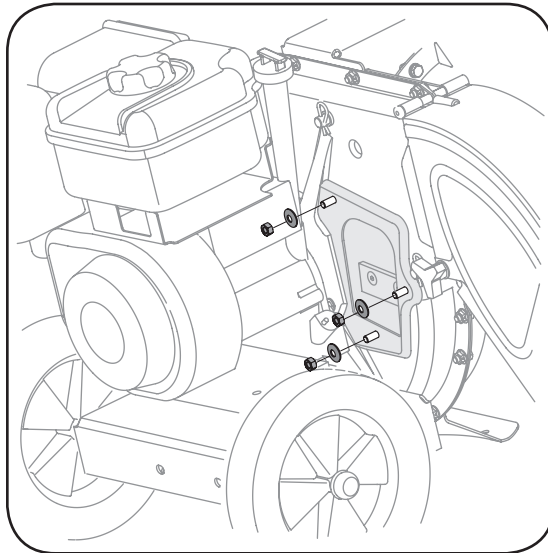

Figure 3-8

7. The chipper shredder was shipped with one end of the support brace already secured to the lower frame. Loosen but do not remove the bolts securing the brace to the frame. See Figure 3-7.
 - a. Align the holes in the chute with the holes in the top of the brace and attach brace to chipper chute with hardware previously removed. Tighten securely.
 - b. Tighten the bolts securing the support brace to the frame.
 - c. Tighten the three nuts on the weld studs holding the chipper chute to the impeller housing.

Attaching The Chipper Chute (Model Series 450)

8. a. Remove the three cupped washers and hex nuts from weld studs around the opening on the side of the impeller housing. See Figure 3-8.

9. a. Align the chipper chute over the weld studs, so the slot in the bottom of the chute is facing down.
- b. Secure chipper chute with the three cupped washers (cupped side against the chipper chute) and hex nuts previously removed. Tighten the nuts at this time. See Figure 3-9.

Attaching The Bag

10. To attach the bag:
 - a. Place the opening of the bag completely over the chute deflector.
 - b. Pull on the drawstring until the bag is tight around chute deflector opening.
 - c. Clip drawstring back on itself, tight against chute deflector to secure into position. See Figure 3-10.

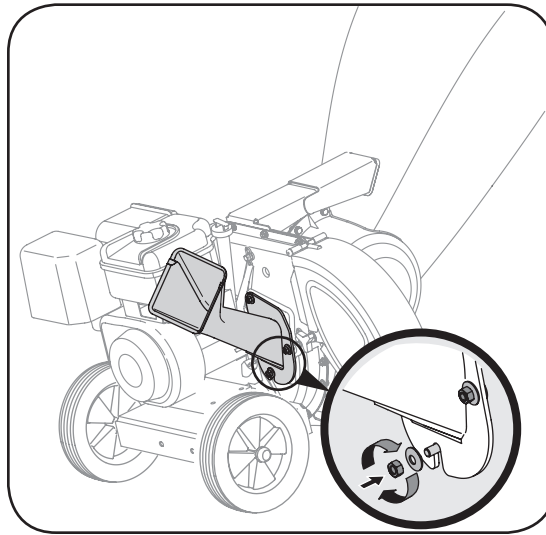

Figure 3-9

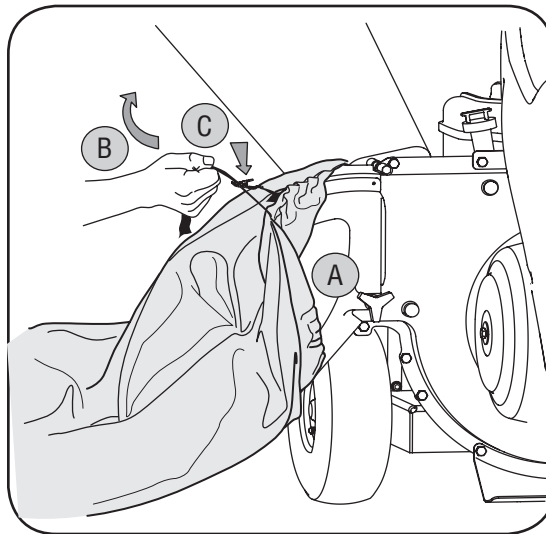

Figure 3-10

3

Setting Up Your Chipper Shredder



IMPORTANT

This unit is shipped without gasoline or oil in the engine. Be certain to service engine with gasoline and oil as instructed in the separate engine manual before operating your machine.

NOTE: All references in this manual to the left or right side of the chipper shredder is from the operating position only. Exceptions, if any, will be specified.

NOTE: This Operators Manual covers a range of product specifications for various models. Characteristics and features discussed and/or illustrated in this manual *may not* be applicable to all models. MTD LLC reserves the right to change product specifications, designs and equipment without notice and without incurring obligation.

4

Operating Your Chipper Shredder



WARNING

The operation of any chipper shredder can result in foreign objects being thrown into the eyes, which can damage your eyes severely. Always wear the safety glasses provided with this unit or eye shields before chipping or shredding and while performing any adjustments or repairs.

Use extreme care when handling gasoline. Gasoline is extremely flammable and the vapors are explosive. *Never* fuel the machine indoors or while the engine is hot or running. Extinguish cigarettes, cigars, pipes and other sources of ignition.

Know Your Chipper Shredder

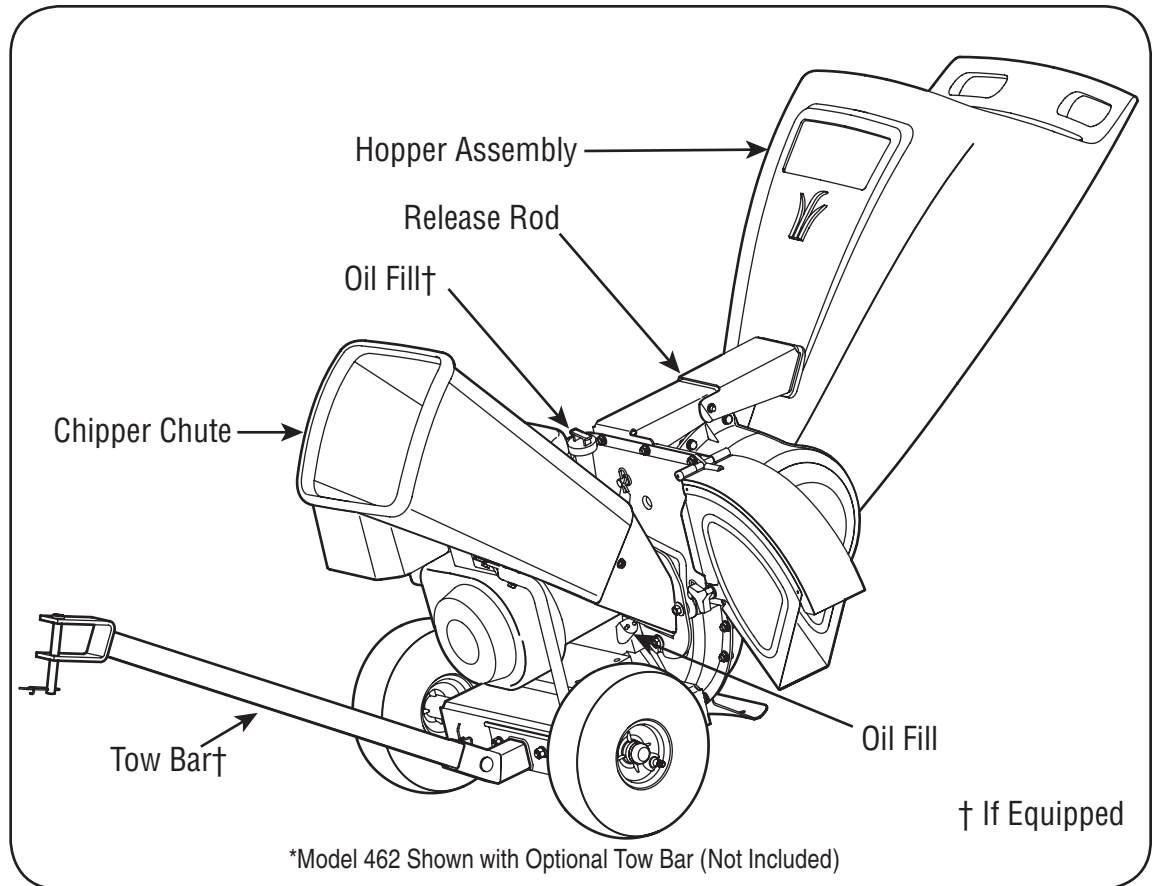

Figure 4-1

Now that you have set up your chipper shredder for operation, get acquainted with its controls and features. These are described below and illustrated on this page. This knowledge will allow you to use your new equipment to its fullest potential.

Chipper Chute

Allows twigs and small branches up to 3" (2" for Model Series 450) in diameter to be fed into the impeller for chipping. See Figure 4-1.

Hopper Assembly

Allow leaves and small branches up to 1/2 diameter to be fed into the impeller for chipping and shredding. Material can be raked into hopper assembly by lowering the hopper assembly. See Figure 4-1.

Release Rod

The release rod is located on the impeller bracket assembly and it is used to release or lock the hopper when raising or lowering. See Figure 4-1.

Tow Bar (If Equipped)

Use the tow bar to tow the chipper shredder behind a tractor to a job site. See Figure 4-1.

NOTE: If your unit is not equipped with a tow bar, you may contact Customer Support as instructed on page 2 for information regarding price and availability.

Gas and Oil Fill-Up

1. Check oil level and add oil if necessary. Follow engine manual for this. See Figure 4-1 above for location of the oil fill.
2. Service the engine with gasoline as instructed in the engine manual. See Figure 4-1 above for location of gas fill.



WARNING: Use extreme care when handling gasoline. Gasoline is extremely flammable and the vapors are explosive. *Never* fuel the machine indoors or while the engine is hot or running. Extinguish cigarettes, cigars, pipes and other sources of ignition.



WARNING: The operation of any chipper shredder can result in foreign objects being thrown into the eyes, which can damage your eyes severely. Always wear the safety glasses provided with this unit or eye shields before chipping or shredding and while performing any adjustments or repairs.

This Operators Manual covers a range of product specifications for various models. Characteristics and features discussed and/or illustrated in this manual *may not* be applicable to all models. MTD LLC reserves the right to change product specifications, designs and equipment without notice and without incurring obligation.

Starting Engine



WARNING: Never run the engine indoors or in a poorly ventilated area. Engine exhaust contains carbon monoxide, an odorless and deadly gas.

IMPORTANT: Because this manual covers several different model units, different starting instructions may apply to your particular engine. Some engines may have a fuel petcock, some may not. Some engines may have On/Off switches, other may not. Some units will utilize a choke system, while others will require priming. These factors depend on what make and model engine comes with your particular unit. For these reasons, please refer to the engine operator's manual for the correct starting procedure.

1. Attach spark plug wire to spark plug. Make certain the metal cap on the end of the spark plug is fastened securely over the metal tip on the spark plug.
2. **Engines with choke lever:**
Move choke lever on engine to CHOKE position. (A warm engine may not require choking).
Engines with primer:
Prime engine as instructed in separate engine manual.
3. The throttle control lever is located on the engine. Move engine throttle control lever to FAST or START position. See Figure 4-2.
4. Grasp starter handle and pull rope out slowly until engine reaches start of compression cycle (rope will pull slightly harder at this point).

NOTE: A noise will be heard when finding the start of the compression cycle. This noise is caused by the flails and fingers, which are part of the shredding mechanism, and it should be expected until the impeller reaches full speed.

5. Pull rope with a rapid, continuous, full arm stroke. Keep a firm grip on starter handle. Let rope rewind slowly.
6. Repeat the previous steps until engine fires. When engine starts, move choke control (if equipped) gradually to RUN position.

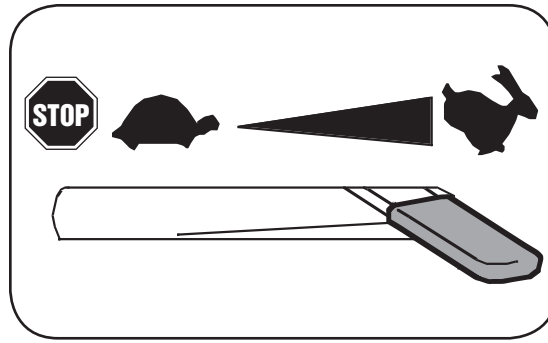

Figure 4-2

Stopping Engine

1. Move throttle control lever to STOP or OFF position.
2. Disconnect spark plug wire from spark plug and ground against the engine.

NOTE: See your engine manual packed with your unit for more detailed instructions.

Using The Chipper Shredder

Yard waste such as leaves and pine needles can be raked up through the hopper assembly for shredding. After material has been shredded by the flail blades on the impeller assembly, it will be discharged out of opening or into catcher bag. Do not attempt to shred or chip any material other than vegetation found in a normal yard (i.e. branches, leaves, twigs, etc.) Avoid fibrous plants such as tomato vines until they are thoroughly dried out. Twigs and small branches up to 3" (2" for Model Series 450) in diameter can be fed into the chipper chute.

Lowering The Hopper Assembly

1. With one hand grasp the handle at the top of the hopper assembly and lift slightly.
2. With the other hand pull out on the release rod and lower the hopper assembly to the ground. See Figure 4-1.

To Empty Bag

1. Un-clip drawstring and loosen bag from chute deflector opening.
2. Empty bag and reattach to the discharge chute opening. Pull on the drawstring until the bag is tight around the chute opening and clip the drawstring tight against the chute deflector.

IMPORTANT: The flail screen is located inside the housing in the discharge area. If the flail screen becomes clogged, remove and clean as instructed in SECTION 5: MAINTAINING YOUR CHIPPER SHREDDER. For best performance, it is also important to keep the chipper blade sharp.

4

Operating Your Chipper Shredder



WARNING

Never run the engine indoors or in a poorly ventilated area. Engine exhaust contains carbon monoxide, an odorless and deadly gas.



NOTE: A noise will be heard when finding the start of the compression cycle. This noise is caused by the flails and fingers, which are part of the shredding mechanism, and it should be expected until the impeller reaches full speed.

5

Maintaining Your Chipper Shredder



WARNING

Always stop engine, disconnect spark plug, and ground against engine before cleaning, lubricating or doing any kind of maintenance on your machine.

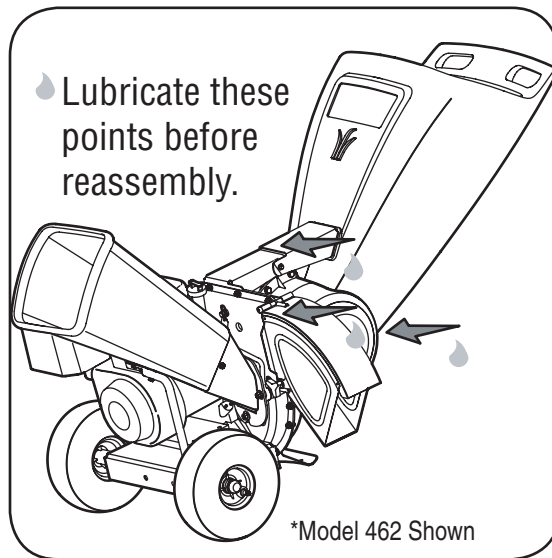

Figure 5-1

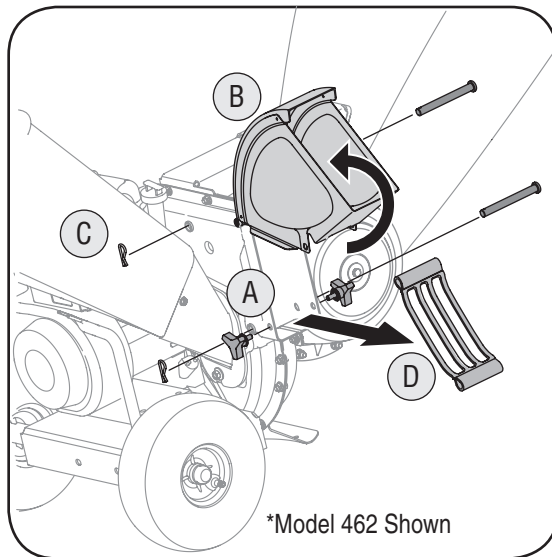

Figure 5-2

General Recommendations

1. Always observe safety rules when performing any maintenance.
2. The warranty on this chipper shredder does not cover items that have been subjected to operator abuse or negligence. To receive full value from warranty, operator must maintain the chipper shredder as instructed here.
3. Changing of engine-governed speed will void engine warranty.
4. All adjustments should be checked at least once each season.
5. Periodically check all fasteners and make sure these are tight.



WARNING: Always stop engine, disconnect spark plug, and ground against engine before cleaning, lubricating or doing any kind of maintenance on your machine.

Lubrication

1. Lubricate the release rod and spring with light oil once a season. See Figure 5-1.
2. Lubricate the pivot points on the hopper assembly with light oil once a season. See Figure 5-1.
3. Lubricate the pivot points on the discharge chute with light oil once a season. See Figure 5-1.
4. Follow the accompanying engine manual for lubrication schedule and instruction for engine lubrication.

Engine Care

1. Maintain oil level as instructed in engine manual.
2. Service air cleaner every 25 hours under normal conditions. Clean every few hours under extremely dusty conditions. Refer to engine manual.
3. Clean spark plug and reset the gap once a season. Check engine manual for correct plug type and gap specifications.
4. Clean engine regularly with a cloth or brush. Keep the cooling system (blower housing area) clean to permit proper air circulation. Remove all grass, dirt and combustible debris from muffler area.

Removing The Flail Screen

If the discharge area becomes clogged, remove the flail screen and clean area as follows:

1. Stop the engine and make certain the chipper shredder has come to a complete stop.
2. Disconnect spark plug wire from spark plug and ground against the engine.
3. a. Remove the bag and two wing knobs on each side of the chute deflector. See Figure 5-2.
b. Lift the chute deflector up to keep it out of the way.
c. Remove the two hairpin clips from each clevis pin which extend through the housing and remove pins.
d. Remove the flail screen from inside the housing and clean the screen by scraping or washing with water. See Figure 5-2.
4. Reinstall the screen, making certain to reassemble the flail screen with the curve side down.
5. Reattach the chute deflector with the hardware previously removed and connect the bag to unit.

Sharpening Or Replacing Chipper Blades

1. Disconnect the spark plug wire and ground against the engine.
2. Remove the flail screen as instructed in the previous section.
3. Remove the chipper chute by removing three hex nuts and washers.
4. Remove the chipper chute support brace (Model Series 460) from the frame by removing the hex bolts.
5. Rotate impeller assembly by hand until you locate one of two chipper blades in the chipper chute opening.

- Remove the blade by removing the internal hex screws, lock washers, and hex nuts which secure it to the impeller. Retain the hardware. See Figure 5-3.

NOTE: Use a 3/16" hex key (Allen) wrench on the outside of the blade and a 1/2" box (or socket) wrench on the inside of the impeller. Hold the Allen wrench stationary and rotate the box (or socket) wrench to loosen the nut.

- Install a replacement blade (Part No. 781-0490) with the hardware removed earlier or sharpen.

IMPORTANT: When sharpening the blade, protect hands by using gloves. Follow the original angle of grind and make sure to remove an equal amount from each blade.

- To replace the other blade, rotate the impeller to expose the second blade and repeat the steps above.

NOTE: Make certain blades are reassembled with the sharp edge facing upward. Torque hardware to 250 - 300 in. lbs.

Sharpening Or Replacing The Shredder Blade



WARNING: The impeller's chipper blades are sharp. Wear leather work gloves to protect your hands.

- Stop the engine and make certain that all moving parts have come to a complete stop.
- Disconnect the spark plug wire and ground against the engine.
- Lower the hopper assembly and block up the housing.
- Remove the six hex lock nuts and flat washers from the weld studs on the flail housing. Retain the hardware.
- Carefully separate the hopper assembly from the impeller assembly and remove the support plate.

NOTE: When reassembling the support plate, make certain the embossed tab faces inward towards the impeller.

- Remove the two wing knobs and cupped washers that secure the chute deflector and raise the chute.
- Insert a 1/2" or 3/4" diameter pipe through the flail screen into the impeller to keep it from turning or remove the flail screen and insert a piece of wood into the chute opening.
- Remove the two internal hex screws, lock washers, and hex lock nuts which secure the shredder blade to the impeller.
 - Remove the hex bolt, lock washer, and flat washer to completely free shredder blade. See Figure 5-4.

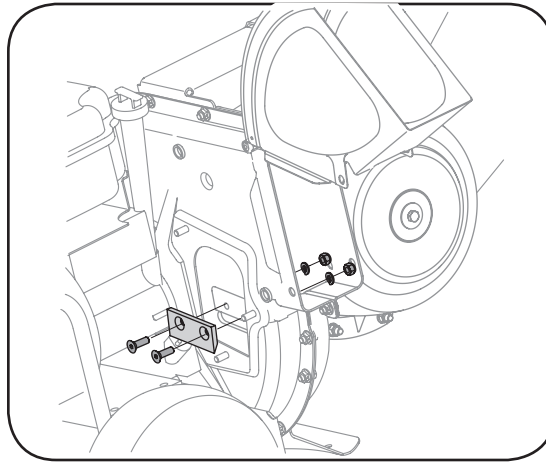

Figure 5-3

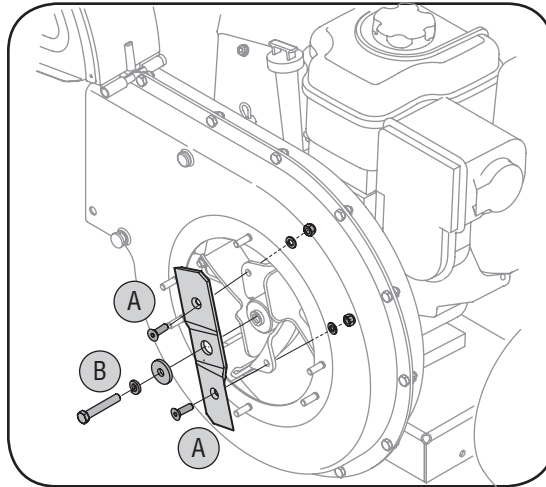

Figure 5-4

NOTE: Use a 3/16" hex key (Allen) wrench on the outside of the shredder blade and a 1/2" box (or socket) wrench on the inside of the shredder blade. Hold the Allen wrench stationary and rotate the box (or socket) wrench to loosen the nut. Use caution when removing the blade to avoid contacting the weld studs on housing.

IMPORTANT: When sharpening the blade, follow the original angle of grind as a guide. It is extremely important that each cutting edge receives an equal amount of grinding to prevent an unbalanced blade. An unbalanced blade will cause excessive vibration when rotating at high speeds and may cause damage to the unit. The blade can be tested by balancing it on a screwdriver or nail. Remove metal from the heavy side until it is balanced evenly.

Storing Your Chipper Shredder

The following steps should be taken to prepare your chipper shredder for storage.

- Clean the equipment thoroughly.
- Wipe equipment with an oiled rag to prevent rust.
- Refer to engine manual for correct engine storage instructions.
- Store unit in a clean, dry area. Do not store next to corrosive materials such as fertilizer.

5

Maintaining Your Chipper Shredder



WARNING

The impeller's chipper blades and shredder blade are sharp. Wear leather work gloves to protect your hands.



IMPORTANT

Make certain chipper blades are reassembled with the sharp edge facing upward. Torque hardware to 250 - 300 in. lbs.

IMPORTANT

When reassembling the shredder blade, tighten center bolt to between 550 and 700 in.-lbs. and the two out bolts to between 250 and 350 in.-lbs.

6

Trouble Shooting



For repairs beyond the minor adjustments listed here, contact an authorized service dealer.

Problem	Cause	Remedy
Engine fails to start	<ol style="list-style-type: none"> 1. Throttle lever not in correct starting position (if equipped). 2. Spark plug wire disconnected. 3. Choke not in CHOKE position (if equipped). 4. Fuel tank empty or stale fuel. 5. Engine not primed (if equipped). 6. Faulty spark plug. 7. Blocked fuel line. 8. Engine flooded. 	<ol style="list-style-type: none"> 1. Move throttle lever to FAST or START position. 2. Connect wire to spark plug. 3. Move choke lever to CHOKE position. 4. Fill tank with clean, fresh gasoline. 5. Prime engine as instructed in Engine Manual. 6. Clean, adjust gap, or replace. 7. Clean fuel line. 8. Wait a few minutes to restart, but do not prime.
Engine runs erratic	<ol style="list-style-type: none"> 1. Spark plug wire loose. 2. Unit running on CHOKE (if equipped). 3. Blocked fuel line or stale fuel. 4. Vent in gas cap plugged. 5. Water or dirt in fuel system. 6. Dirty air cleaner. 7. Carburetor out of adjustment. 	<ol style="list-style-type: none"> 1. Connect and tighten spark plug wire. 2. Move choke lever to OFF position. 3. Clean fuel line; fill tank with clean, fresh gasoline. 4. Clear vent. 5. Drain fuel tank. Refill with fresh fuel. 6. Refer to engine manual. 7. See authorized service dealer.
Engine overheats	<ol style="list-style-type: none"> 1. Engine oil level low. 2. Dirty air cleaner. 3. Carburetor not adjusted properly. 	<ol style="list-style-type: none"> 1. Fill crankcase with proper oil. 2. Refer to engine manual. 3. See authorized service dealer.
Occasional skips (hesitates) at high speed	<ol style="list-style-type: none"> 1. Spark plug gap too close. 2. Carburetor idle mixture adjustment improperly set. 	<ol style="list-style-type: none"> 1. Adjust gap to .030". 2. See authorized service dealer.
Excessive Vibration	<ol style="list-style-type: none"> 1. Loose parts or damaged impeller. 	<ol style="list-style-type: none"> 1. See authorized service dealer.
Unit does not discharge	<ol style="list-style-type: none"> 1. Chute deflector clogged. 2. Foreign object lodged in impeller. 3. Low engine RPM. 	<ol style="list-style-type: none"> 1. Stop engine immediately and disconnect spark plug wire. Clean flail screen and inside of discharge opening. 2. Stop engine and disconnect spark plug wire. Remove lodged object. 3. Always run engine at full throttle.
Rate of discharge slows considerably or composition of discharged material changes	<ol style="list-style-type: none"> 1. Low engine RPM. 2. Chipper blade dull. 	<ol style="list-style-type: none"> 1. Always run engine at full throttle. 2. Replace chipper blade or see your authorized service dealer.

NOTES

Use this page to make notes and write down important information.

Model Series 452 Thru 465

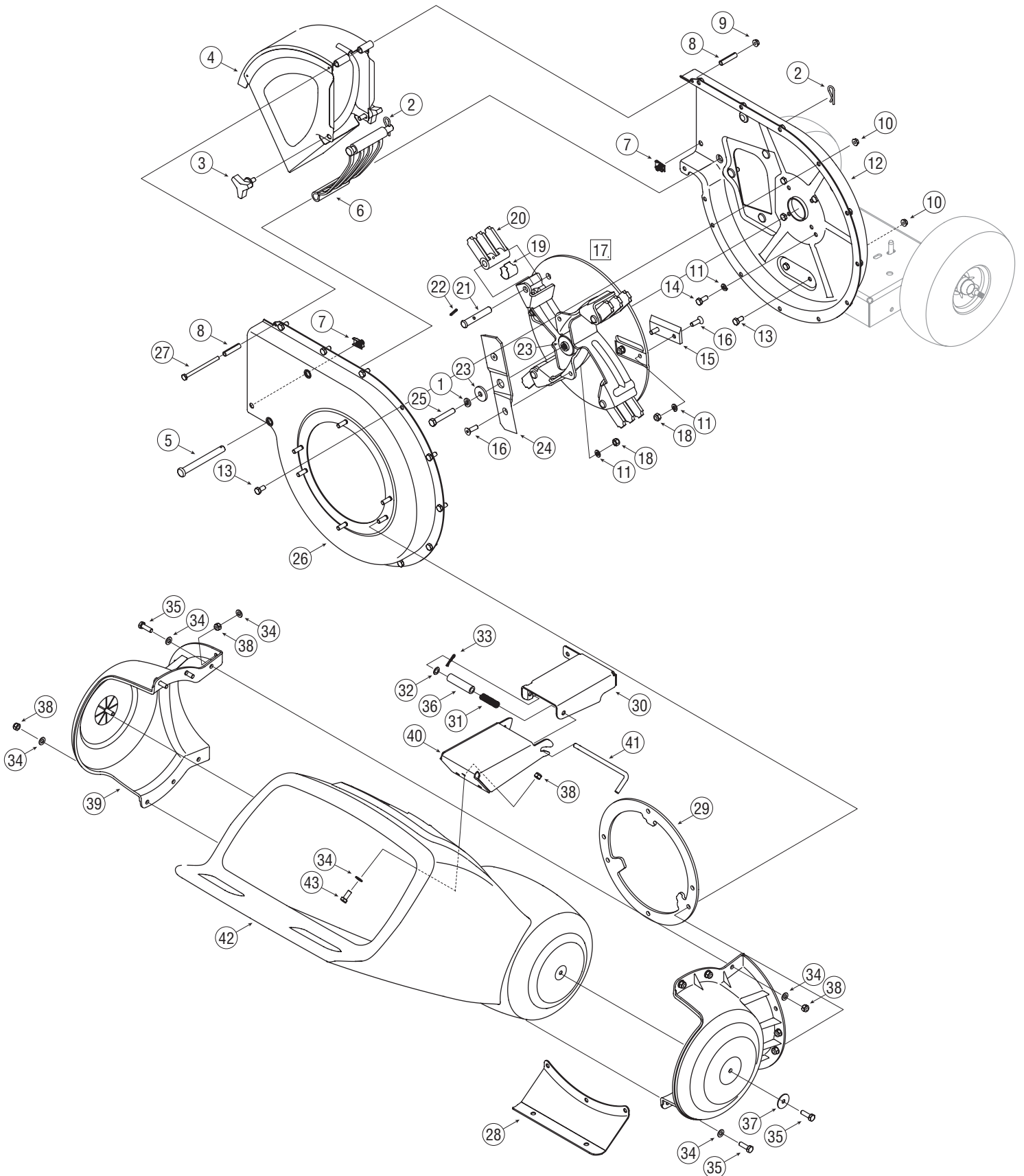

7

Parts List



To order replacement parts, contact
1-800-800-7310 or visit
www.mtdproducts.com

NOTE: This Operators Manual covers a range of product specifications for various models. Characteristics and features discussed and/or illustrated in this manual *may not* be applicable to all models. MTD LLC reserves the right to change product specifications, designs and equipment without notice and without incurring obligation.

Ref. No.	Part No.	Description
1.	736-0217	Lock Washer, 3/8
2.	714-0149B	Cotter Pin
3.	681-0048	Wing Knob 5/16-18
4.	681-0094	Chute Deflector Assembly
5.	711-0835	Clevis Pin
6.	781-0457	Shredder Screen
7.	726-0211	U-Nut 5/16-18
8.	750-0793	Spacer
9.	712-3027	Hex Lock Nut 1/4-20
10.	712-3004A	Hex Lock Nut 5/16-18
11.	736-0119	Lock Washer 5/16
12.	681-0117	Inner Impeller Housing Assembly
13.	710-3025	Hex Cap Screw 5/16-18 x.625
14.	710-0157	Hex Cap Screw 5/16-24 x.75
15.	781-0490	Chipper Blade
16.	710-1054	Hex Cap Screw 5/16-24 x 1.0
17.	681-0030	Impeller Assembly
18.	712-0411	Hex Lock Nut 5/16-24
19.	781-0735	Retainer Pin Clip
20.	719-0329	Flail Blade
21.	711-0833B	Clevis Pin
22.	715-0166	Pin
23.	736-0247	Flat Washer 3/8 x 1.25
24.	742-0571	Shredder Blade
25.	710-1254	Hex Cap Screw 3/8-24 x 2.25
26.	681-0004A	Outer Impeller Housing Assembly
27.	710-0825	Hex Cap Screw 1/4-20 x 3.75
28.	781-0515	Front Support Bracket
29.	781-0574	Shredder Plate
30.	681-0104	Rear Hopper Bracket Assembly
31.	732-0306	Compression Spring 1.75
32.	736-0117	Flat Washer
33.	714-0104	Cotter Pin
34.	736-0264	Flat Washer.330 ID x.630 OD
35.	710-0376	Hex Cap Screw 5/16-18 x 1.0
36.	748-0453	Spacer,.375 ID x 2.50 LG
37.	736-0362	Flat Washer.320 ID x 1.25 OD
38.	712-0429	Hex Lock Nut 5/16-18
39.	731-1710A	Hopper Collar
40.	681-0123	Front Hopper Bracket Assembly
41.	711-1128	Lock Rod
42.	731-1707	Hopper Assembly
43.	710-3008	Hex Cap Screw 5/16-18 x.75

Model Series 452 Thru 465

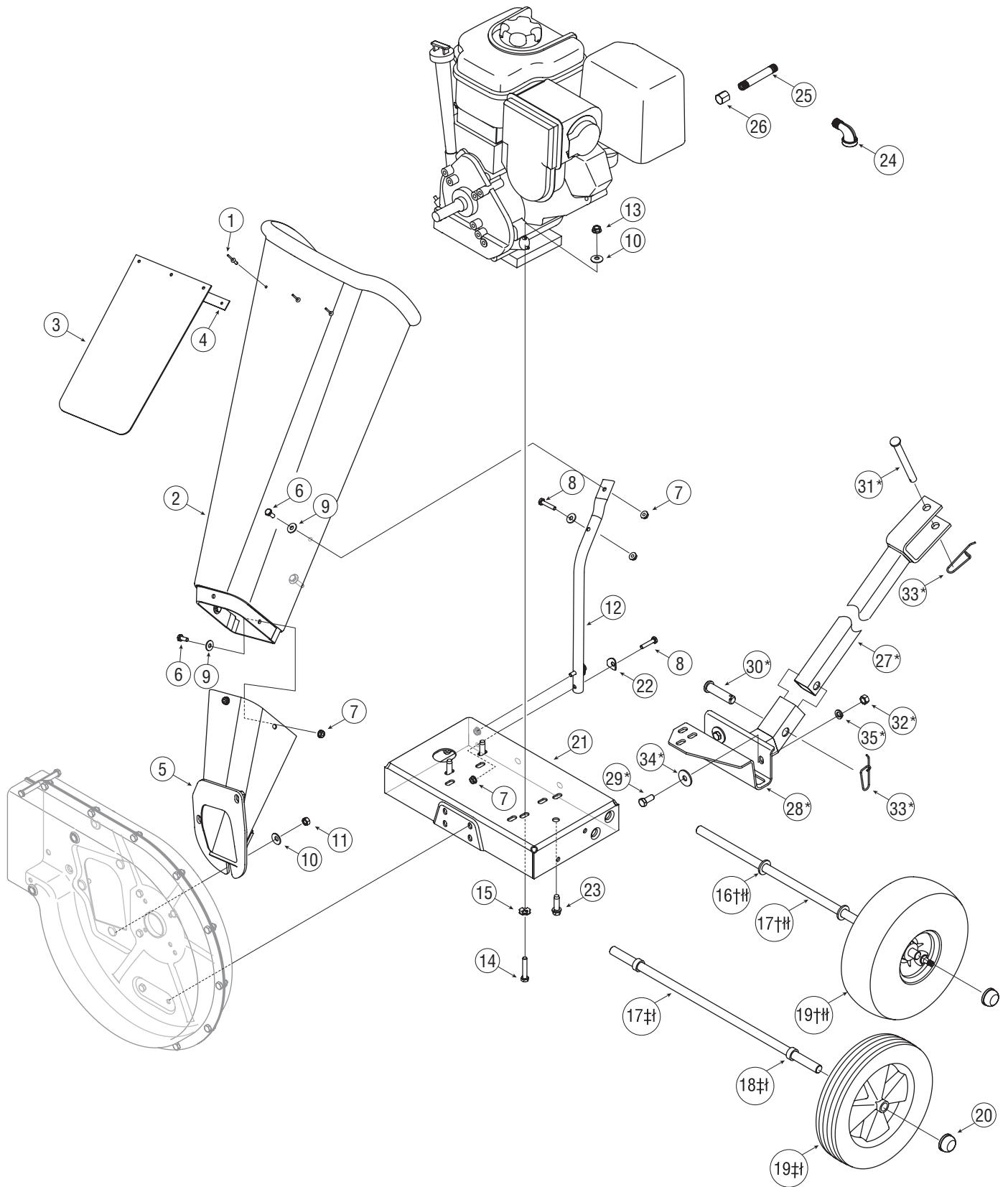

† # Model Series 454 & 464
 ‡ † Model Series 452 & 462
 * If Equipped

7

Parts List



To order replacement parts, contact
1-800-800-7310 or visit
www.mtdproducts.com

NOTE: This Operators Manual covers a range of product specifications for various models. Characteristics and features discussed and/or illustrated in this manual *may not* be applicable to all models. MTD LLC reserves the right to change product specifications, designs and equipment without notice and without incurring obligation.

Ref. No.	Part No.	Description
1.	728-0175	Pop Rivet
2.	731-1899	Chipper Shredder Chute
	681-0095 † ‡	Chipper Shredder Chute
3.	735-0249	Chute Flap
4.	781-0633	Chute Flap Strip
5.	681-0068A	Chipper Chute Assembly
6.	710-0751	Hex Cap Screw 1/4 -20 x.620
7.	712-3027	Hex Lock Nut 1/4-20
8.	710-0106	Hex Cap Screw 1/4-20 x 1.25
9.	736-0173	Flat Washer,.28 ID x.74 OD
10.	736-0242	Bell Washer.340 ID x.872 OD
11.	712-3010	Hex Nut 5/16-18
12.	749-1004	Support Brace
13.	712-3004A	Hex Lock Nut 5/16-18
14.	710-0805 † ‡	Hex Cap Screw 5/16-18 x 1.50
	710-3180 † †	Hex Cap Screw 5/16-18 x 1.75
15.	736-0170	Bell Washer 5/16 x 1.0
16.	736-0366 † ‡	Flat Washer
17.	738-0814 ‡ †	Axle Assembly
	738-0813 † ‡	Axle Assembly
18.	750-0786 ‡ †	Spacer
19.	734-1600 ‡ †	Wheel Comp., 10.0 x 2.5 Plastic
	734-1845 † ‡	Wheel Complete, 10.0 x 4.0 Gray
20.	726-0214	Push Cap
21.	681-0184A † † ‡	Frame
	681-0183A † †	Frame
22.	736-0451	Washer,.320 ID x.93 OD
23.	710-0502A	Screw, 3/8-16 x 1.250
24.	737-0195 ^ † ‡	Elbow Fitting
25.	737-0298 † †	Oil Drain Pipe
26.	737-0132 † †	Oil Drain End Cap
27.	681-0133*	Tongue Hitch Mount
28.	681-0134A*	Base Hitch Mount
29.	710-3001*	Hex Cap Screw, 3/8-16 x.88
30.	711-0299*	Clevis Pin,.625 x 2.4
31.	711-0835*	Clevis Pin,.50 x 4.62
32.	712-3017*	Hex Nut, 3/8-16
33.	732-0194*	Spring Pin
34.	736-0133*	Flat Washer,.411 x 1.25 x 1.0
35.	736-0169*	Lock Washer, 3/8
—	723-0400	Safety Glasses (Not Shown)
—	664-04022	Chipper Bag Ass'y (Not Shown)
—	664-04023 † † † †	Chipper Bag Ass'y (Not Shown)

† Model Series 464
 † † Model 464G Only
 ‡ Model Series 462
 † Models 452
 ‡ Models 454
 ^ Models 462 & 464D
 * If Equipped
 † Models 465

MANUFACTURER'S LIMITED WARRANTY FOR



The limited warranty set forth below is given by MTD LLC with respect to new merchandise purchased and used in the United States, its possessions and territories.

"MTD" warrants this product against defects in material and workmanship for a period of two (2) years commencing on the date of original purchase and will, at its option, repair or replace, free of charge, any part found to be defective in materials or workmanship. This limited warranty shall only apply if this product has been operated and maintained in accordance with the Operator's Manual furnished with the product, and has not been subject to misuse, abuse, commercial use, neglect, accident, improper maintenance, alteration, vandalism, theft, fire, water, or damage because of other peril or natural disaster. Damage resulting from the installation or use of any part, accessory or attachment not approved by MTD for use with the product(s) covered by this manual will void your warranty as to any resulting damage.

Normal wear parts are warranted to be free from defects in material and workmanship for a period of thirty (30) days from the date of purchase. Normal wear parts include, but are not limited to items such as: batteries, belts, blades, blade adapters, grass bags, rider deck wheels, seats, snow thrower skid shoes, shave plates, auger spiral rubber and tires.

HOW TO OBTAIN SERVICE: Warranty service is available, WITH PROOF OF PURCHASE, through your local authorized service dealer. To locate the dealer in your area, check your Yellow Pages, or contact MTD LLC at P.O. Box 361131, Cleveland, Ohio 44136-0019, or call 1-800-800-7310 or 1-330-220-4683 or log on to our Web site at www.mtdproducts.com.

This limited warranty does **not** provide coverage in the following cases:

- a. The engine or component parts thereof. These items may carry a separate manufacturer's warranty. Refer to applicable manufacturer's warranty for terms and conditions.
- b. Log splitter pumps, valves, and cylinders have a separate one year warranty.
- c. Routine maintenance items such as lubricants, filters, blade sharpening, tune-ups, brake adjustments, clutch adjustments, deck adjustments, and normal deterioration of the exterior finish due to use or exposure.
- d. Service completed by someone other than an authorized service dealer.

e. MTD does not extend any warranty for products sold or exported outside of the United States, its possessions and territories, except those sold through MTD's authorized channels of export distribution.

f. Replacement parts that are not genuine MTD parts.

g. Transportation charges and service calls.

No implied warranty, including any implied warranty of merchantability of fitness for a particular purpose, applies after the applicable period of express written warranty above as to the parts as identified. No other express warranty, whether written or oral, except as mentioned above, given by any person or entity, including a dealer or retailer, with respect to any product, shall bind MTD. During the period of the warranty, the exclusive remedy is repair or replacement of the product as set forth above.

The provisions as set forth in this warranty provide the sole and exclusive remedy arising from the sale. MTD shall not be liable for incidental or consequential loss or damage including, without limitation, expenses incurred for substitute or replacement lawn care services or for rental expenses to temporarily replace a warranted product.

Some states do not allow the exclusion or limitation of incidental or consequential damages, or limitations on how long an implied warranty lasts, so the above exclusions or limitations may not apply to you.

In no event shall recovery of any kind be greater than the amount of the purchase price of the product sold. **Alteration of safety features of the product shall void this warranty.** You assume the risk and liability for loss, damage, or injury to you and your property and/or to others and their property arising out of the misuse or inability to use the product.

This limited warranty shall not extend to anyone other than the original purchaser or to the person for whom it was purchased as a gift.

HOW STATE LAW RELATES TO THIS WARRANTY: This limited warranty gives you specific legal rights, and you may also have other rights which vary from state to state.

IMPORTANT: Owner must present Original Proof of Purchase to obtain warranty coverage.